

~FIRST SOUTH~

~CARBON AVENUE~

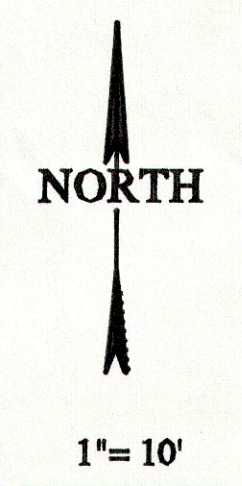
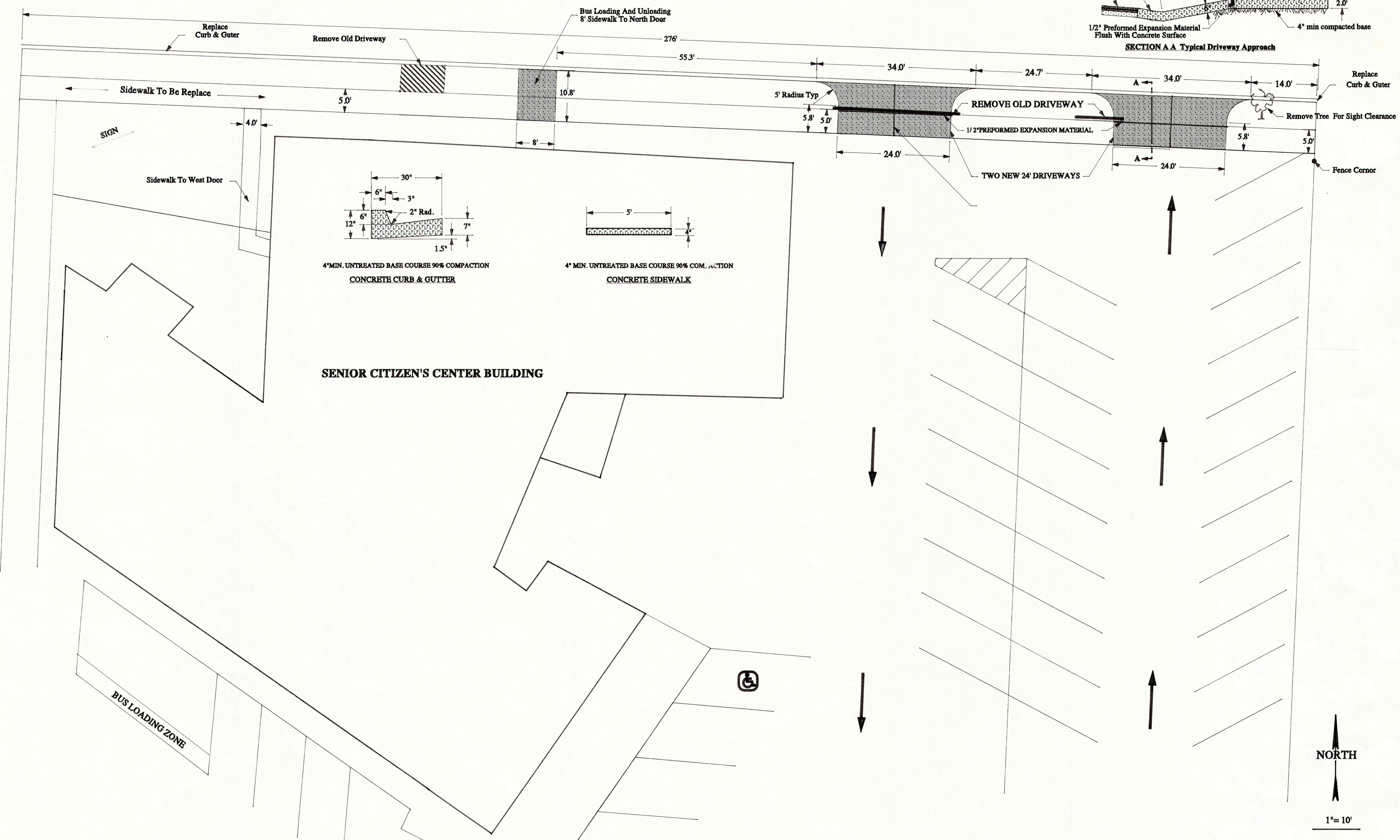
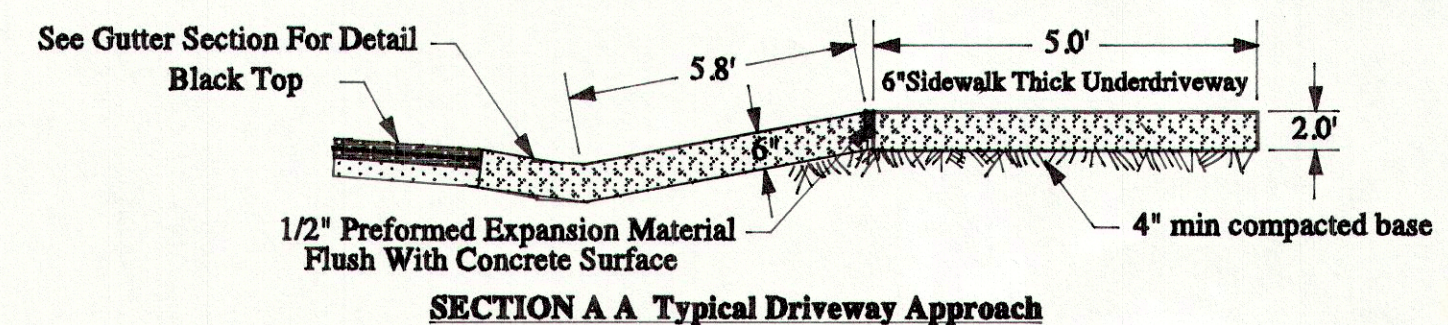

SENIOR CITIZEN'S CENTER		
~Curbs, & Gutters, Sidewalk & Driveways~ First South and 50 East		
CARBON COUNTY ENGINEERING DEPT.		
SCALE 1" = 10'	Dec. 3, 1998	1 of 1

NOTE: Concret 6.5 bag mix with a 3" slump  
broom finish on the sidewalk and driveway.  
6" minimum untreated base course  
90% compaction under sidewalk and driveway.